

SEMIPACK® 1 Fast Diode Modules

SKKD 42 F
SKMD 42 F
SKND 42 F

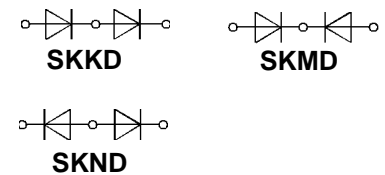

Features

- Heat transfer through ceramic isolated metal baseplate
- Hard soldered joints for high reliability
- **SKKD** half bridge connection
centre tap connections:
SKMD common cathode
SKND common anode
- UL recognized, file no. E 63 532

Typical Applications

- Self-commutated inverters
- DC choppers
- AC motor speed control
- Inductive heating
- Uninterruptible power supplies
- Electronic welders
- General power switching applications

V_{RSM} V_{RRM} V	I_{FRMS} (maximum value for continuous operation) 120 A		
	I_{FAV} (sin. 180; $T_{case} = 85\text{ °C}$; 50 Hz) 42 A		
1000	SKKD 42 F 10	SKMD 42 F 10	–
1200	SKKD 42 F 12	SKMD 42 F 12	SKND 42 F 12
1400	SKKD 42 F 14	SKKD 42 F 14	SKND 42 F 14
1500	SKKD 42 F 15	SKMD 42 F 15	SKKD 42 F 15

Symbol	Conditions	SKKD 42 F SKMD 42 F SKND 42 F	Units
I_{FAV}	sin. 180; $T_{case} = 85\text{ °C}$	42	A
I_{FSM}	$T_{vj} = 25\text{ °C}$; 10 ms $T_{vj} = 130\text{ °C}$; 10 ms	1 200 1 100	A A
i^2t	$T_{vj} = 25\text{ °C}$; 8,3 ... 10 ms $T_{vj} = 130\text{ °C}$; 8,3 ... 10 ms	7 200 6 000	A^2s A^2s
t_{rr}	$T_{vj} = 25\text{ °C}$; $I_F = 1\text{ A}$; $di_F/dt = 15\text{ A}/\mu s$; $V_R = 30\text{ V}$	0,7	μs
Q_{rr}	} $T_{vj} = 130\text{ °C}$; $I_F = 50\text{ A}$; – $di_F/dt = 50\text{ A}/\mu s$; $V_R = 30\text{ V}$	75	μC
I_{RM}		70	A
I_R	$T_{vj} = 25\text{ °C}$; $V_R = V_{RRM}$	0,4	mA
I_R	$T_{vj} = 130\text{ °C}$; $V_R = V_{RRM}$	30	mA
V_F	$T_{vj} = 25\text{ °C}$; $I_{FM} = 150\text{ A}$; max.	1,85	V
$V_{(TO)}$	$T_{vj} = 130\text{ °C}$	1,0	V
r_T	$T_{vj} = 130\text{ °C}$	5	m Ω
R_{thjc}	per diode / per module	0,7 / 0,35	$^{\circ}C/W$
R_{thch}	per diode / per module	0,2 / 0,1	$^{\circ}C/W$
T_{vj}		– 40 ... + 130	$^{\circ}C$
T_{stg}		– 40 ... + 125	$^{\circ}C$
V_{isol}	a. c. 50 Hz; r.m.s; 1 s/1 min to heatsink } SI (US) units to terminals } approx.	3600 / 3000	V~
M_1		5 (44 lb. in.) $\pm 15\%$	Nm
M_2		3 (26 lb. in.) $\pm 15\%$	Nm
w		120	g
Case	→ page B 2 – 6	SKKD: A 10 SKMD: A 33 SKND: A 37	

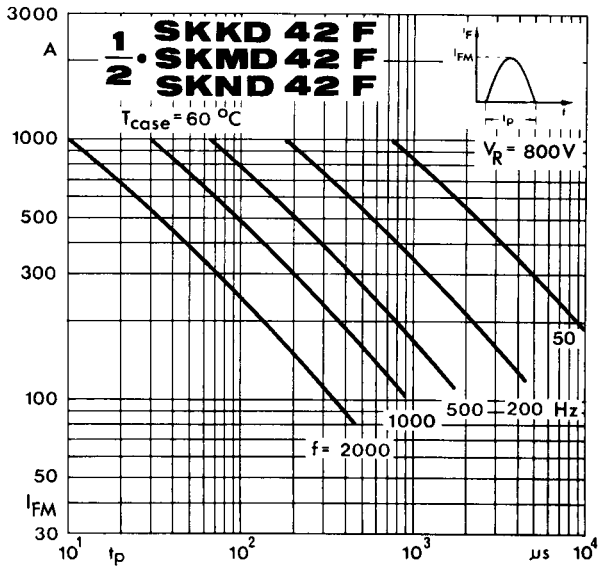

Fig. 12 a Rated sinusoidal peak forward current

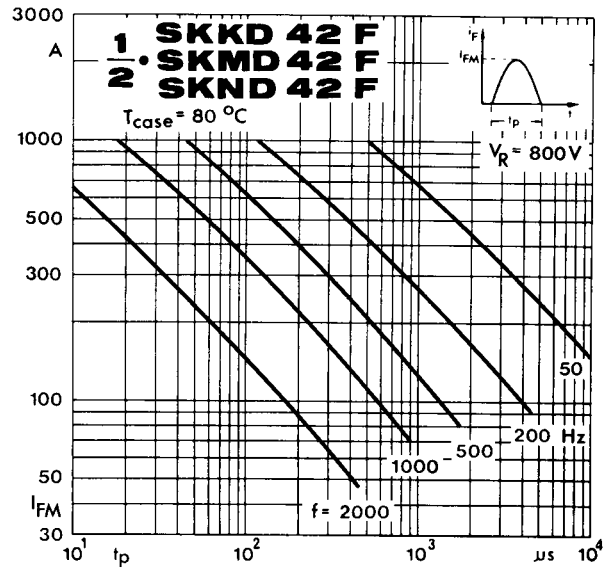

Fig. 12 b Rated sinusoidal peak forward current

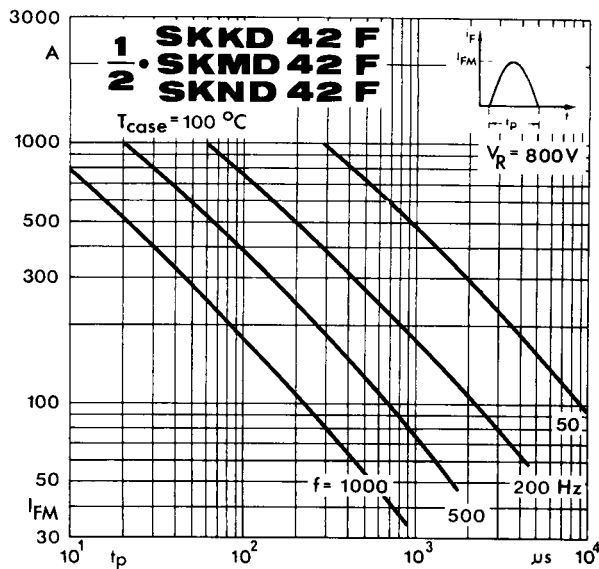

Fig. 12 c Rated sinusoidal peak forward current

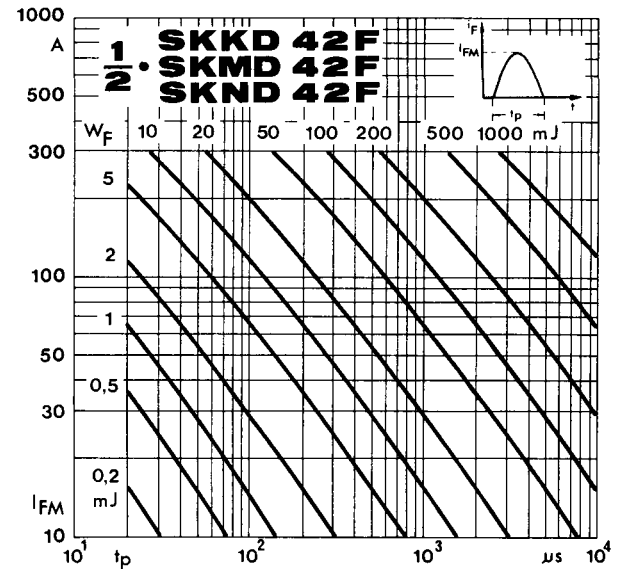

Fig. 13 Forward energy dissipation, sinusoidal

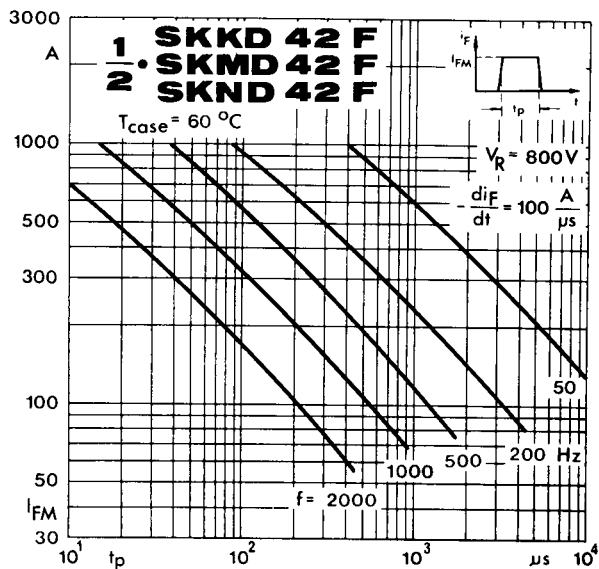

Fig. 14 a Rated rectangular peak forward current

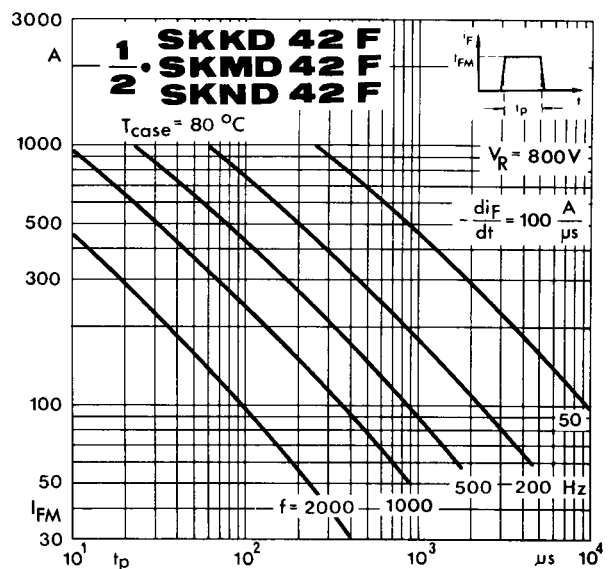

Fig. 14 b Rated rectangular peak forward current

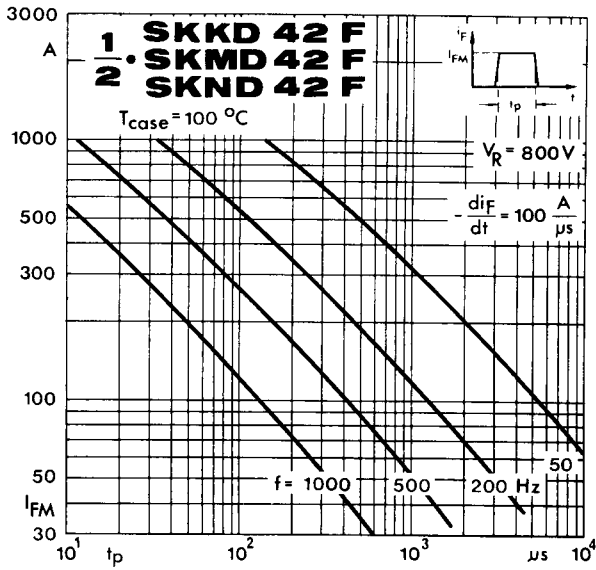

Fig. 14 c Rated rectangular peak forward current

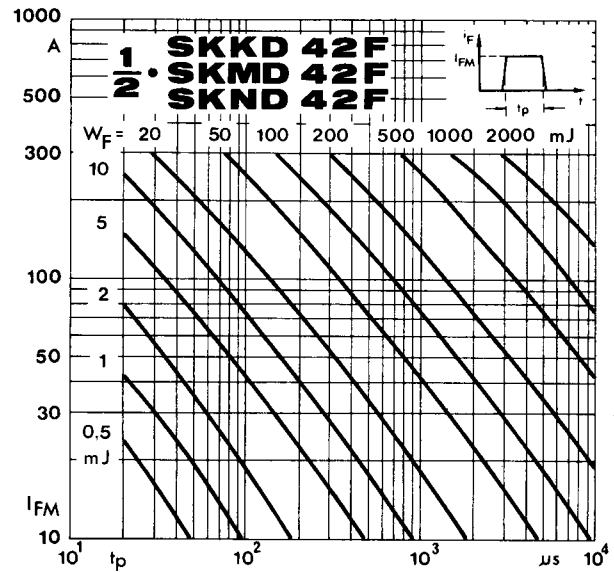

Fig. 15 Forward energy dissipation, rectangular

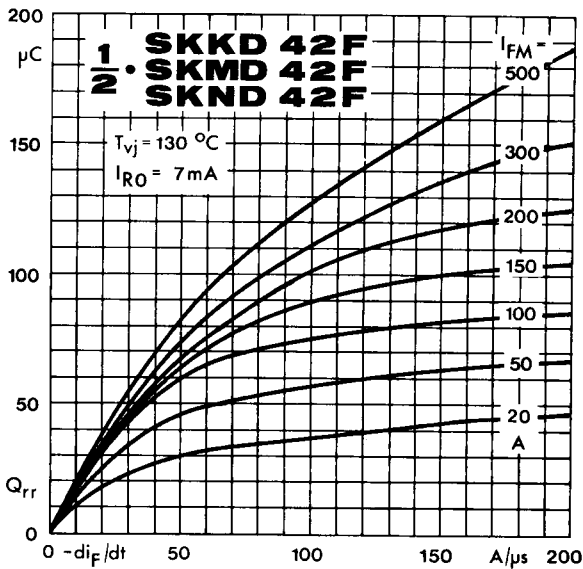

Fig. 16 Recovered charge vs. current decrease

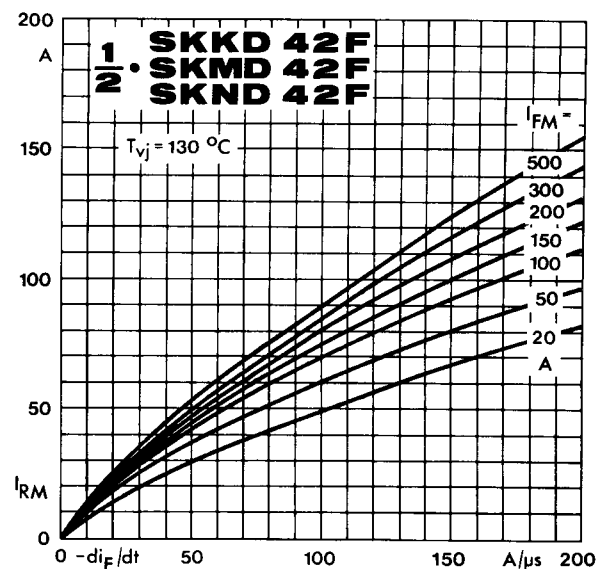

Fig. 17 Peak recovery current vs. current decrease

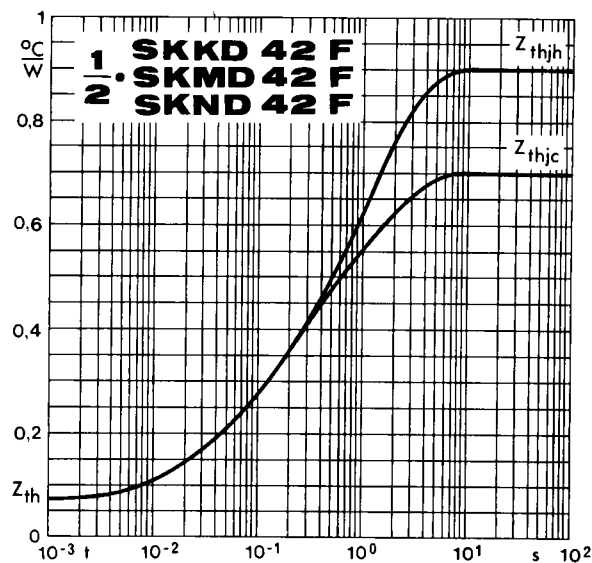

Fig. 18 Transient thermal impedance vs. time

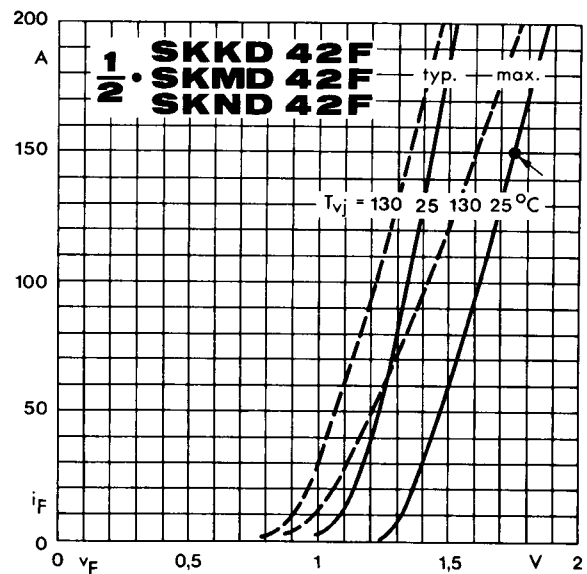

Fig. 19 Forward characteristics

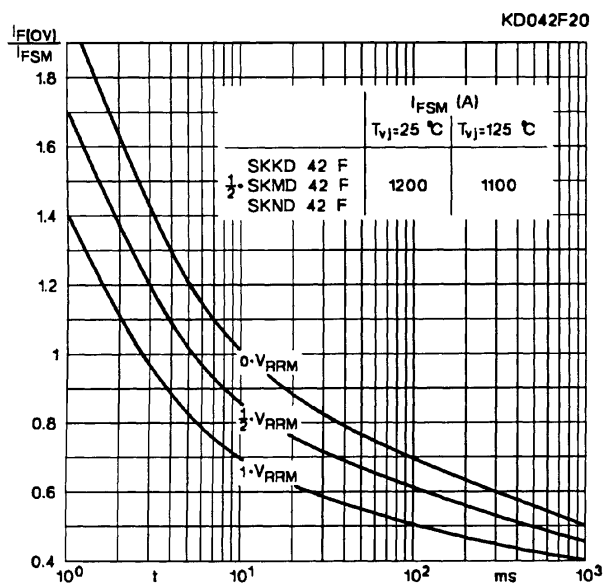

Fig. 20 Surge overload current vs. time

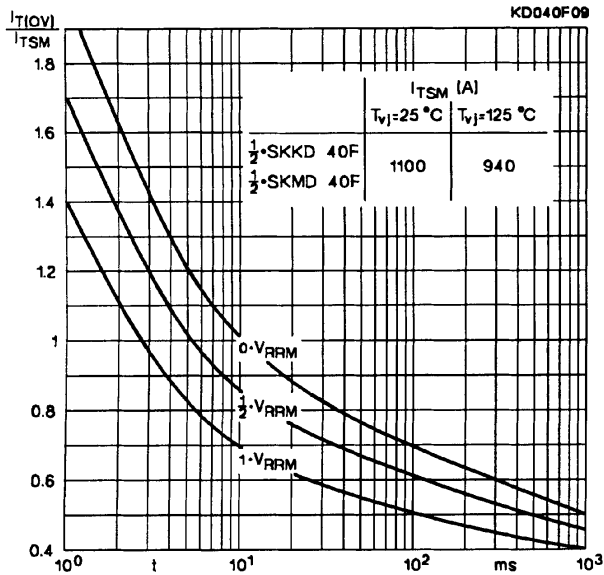

Fig. 20 Surge overload current vs. time

SKKD 40 F, 42 F

Case A 10

IEC 192-2: A 77 A
JEDEC: TO-240 AA

SEMIPACK 1®

UL recognized, file no. E 63 532

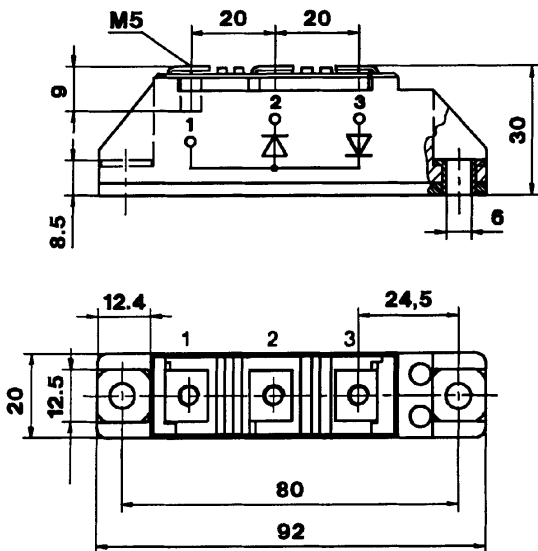

Dimensions in mm

SKMD 40 F
Case A11

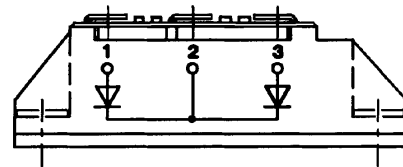

SKMD 42 F
Case A 33

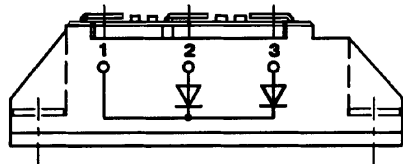

SKND 42 F
Case A 37

