

SKiiP 1092 GB 170 - 474 CTV

Absolute Maximum Ratings			
Symbol	Conditions ¹⁾	Values	Units
V _{isol} ⁴⁾	AC, 1min	4000	V
T _{op} , T _{stg}	Operating / stor. temperature	-25...+85	°C
IGBT and Inverse Diode			
V _{CES}		1700	V
V _{CC} ⁵⁾	Operating DC link voltage	1200	V
I _C	IGBT	1000	A
T _j ³⁾	IGBT + Diode	-40...+150	°C
I _F	Diode	1000	A
I _{FM}	Diode, t _p < 1 ms	2000	A
I _{FSM}	Diode, T _j = 150 °C, 10ms; sin	8640	A
I ² t (Diode)	Diode, T _j = 150 °C, 10ms	373	kAs ²
Driver			
V _{S1}	Stabilized Power Supply	18	V
V _{S2}	Non-stabilized Power Supply	30	V
f _{smax}	Switching frequency	7,0	kHz
dV/dt	Primary to secondary side	75	kV/μs

Characteristics					
Symbol	Conditions ¹⁾	min.	typ.	max.	Units
IGBT ¹¹⁾					
V _{(BR)CES}	Driver without supply	≥V _{CES}	-	-	V
I _{CES}	V _{GE} = 0, T _j = 25 °C	-	-	4	mA
	V _{CE} = V _{CES} T _j = 125 °C	-	60	-	mA
V _{TO}	T _j = 125 °C	-	-	1,77	V
r _T	T _j = 125 °C	-	-	4,1	mΩ
V _{Cesat}	I _C = 800A, T _j = 125 °C	-	-	5,1	V
V _{Cesat}	I _C = 800A, T _j = 25 °C	-	-	3,85	V
E _{on} + E _{off}	V _{CC} =900/1200V, I _C =1000A T _j = 125 °C	-	-	845/130 1	mJ
C _{CHC}	per Phase, AC side	-	3,2	-	nF
L _{CE}	Top, Bottom	-	2	-	nH
Inverse Diode ²⁾					
V _F = V _{EC}	I _F = 800A; T _j = 125 °C	-	-	2,60	V
V _F = V _{EC}	I _F = 800A; T _j = 25 °C	-	-	2,90	V
E _{on} + E _{off}	I _F = 1000A; T _j = 125 °C	-	-	120	mJ
V _{TO}	T _j = 125 °C	-	-	0,90	V
r _T	T _j = 125 °C	-	-	1,3	mΩ
Thermal Characteristics					
R _{thjs} ¹⁰⁾	per IGBT	-	-	0,023	K/W
R _{thjs} ¹⁰⁾	per Diode	-	-	0,063	K/W
R _{thsa} ^{6,10)}	P16 heatsink; see case S4	-	-	33	K/KW
Driver					
I _{S1}	Supply current 15V-supply	290+490*f _s /f _{smax} +1,3*I _{AC} /A			mA
I _{S2}	Supply current 24V-supply	220+370*f _s /f _{smax} +1,0*I _{AC} /A			mA
t _{interlock-driver}	Interlock-time	3,0			μs
SKiiPPACK protection					
I _{TRIPSC}	Short circuit protection	1250			A
I _{TRIPLG}	Ground fault protection	-			A
T _{TRIP}	Over-temp. protection	115			°C
U _{DCTRIP} ⁹⁾	U _{DC} -protection	1225			V
Mechanical Data					
M1	DC terminals, SI Units	4	-	6	Nm
M2	AC terminals, SI Units	8	-	10	Nm

SKiiPPACK®

SK integrated intelligent Power PACK halfbridge

SKiiP

1092 GB 170 - 474 CTV ^{7,9)}

Preliminary Data

Case S4

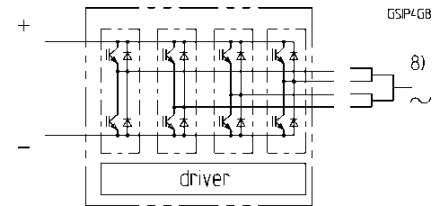

Features

- Short circuit protection, due to evaluation of current sensor signals
- Isolated power supply
- Low thermal impedance
- Optimal thermal management with integrated heatsink
- Pressure contact technology with increased power cycling capability, compact design
- Low stray inductance
- High power, small losses
- Over-temperature protection

- 1) T_{heatsink} = 25 °C, unless otherwise specified
- 2) CAL = Controlled Axial Lifetime Technology (soft and fast)
- 3) without driver
- 4) Driver input to DC link / AC output to DC link / AC output to heatsink
- 5) with Semikron-DC link (low inductance)
- 6) other heatsinks on request
- 7) C - Integrated current sensors
T - Temperature protection
V - 15 V or 24 V power supply
- 8) AC connection busbars must be connected by the user; copper busbars available on request
- 9) options available for driver:
U - DC link voltage sense
F - Fiber optic connector
- 10) "s" referenced to temperature sensor

PIN-array - halfbridge driver SKiiPACK 4-fold type "GB"

X1:

Pin	signal	remark
1	shield	connected to GND, when shielded cable is used
2	BOT IN ⁴⁾	positive 15V CMOS logic; 10 kΩ impedance, don't connect when using fiber optic
3	ERROR OUT ¹⁾	LOW = NO ERROR; open Collector Output; max. 30 V / 15 mA don't connect when using fiber optic, propagation delay 1 μs min. pulsewidth error-memory-reset 8 μs
4	TOP IN ⁴⁾	positive 15V CMOS logic; 10 kΩ impedance don't connect when using fiber optic
5	Overtemp. OUT ¹⁾	LOW = NO ERROR = $\vartheta_{DCB} < 115 \pm 5^\circ\text{C}$ open collector Output; max. 30 V / 15 mA „low“ output voltage < 0,6 V „high“ output voltage max. 30 V
6	+ 24 V _{DC} IN	24 V _{DC} (20 - 30 V)
7	+ 24 V _{DC} IN	don't supply with 24 V, when using + 15 V _{DCIN} supply voltage monitoring threshold 19,5 V
8	+ 15 V _{DC} IN	15 V _{DC} ± 4 %
9	+ 15 V _{DC} IN	don't supply with 15 V, when using + 24 V _{DCIN} supply voltage monitoring threshold 13 V
10	GND	GND for power supply and
11	GND	GND for digital signals
12	Temp. analog OUT or U _{DC} analog OUT ²⁾	U _{DC} when using option "U" actual DC-link voltage, 9 V refer to U _{DCmax} max. output current 5 mA; overvoltage trip level 9 V
13	GND aux ³⁾	GND for analog signals
14	I analog OUT	current actual value, 8,0 V refer to I _C @ 25 °C overcurrent trip level 10 V ⇔ 125 % I _C @ 25 °C current value > 0 ⇔ SKiiP is source current value < 0 ⇔ SKiiP is sink

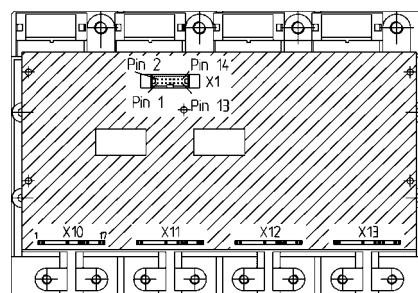

X10: halfbridge 1 (HB1) OUT

Pin	Signal
1	
2	
8	Collector TOP (HB1)
11	Gate TOP (HB1)
12	Emitter TOP (HB1)
13	Collector BOT (HB1)
16	Gate BOT (HB1)
17	Emitter BOT (HB1)

X11: halfbridge 2 (HB2) OUT

Pin	Signal
1	Temp.-Sensor (HB2)1
2	Temp.-Sensor (HB2)2
8	Collector TOP (HB2)
11	Gate TOP (HB2)
12	Emitter TOP (HB2)
13	Collector BOT (HB2)
16	Gate BOT (HB2)
17	Emitter BOT (HB2)

X12: halfbridge 3 (HB3) OUT

Pin	Signal
1	
2	
8	Collector TOP (HB3)
11	Gate TOP (HB3)
12	Emitter TOP (HB3)
13	Collector BOT (HB3)
16	Gate BOT (HB3)
17	Emitter BOT (HB3)

X13: halfbridge 4 (HB4) OUT

Pin	Signal
1	
2	
8	Collector TOP (HB4)
11	Gate TOP (HB4)
12	Emitter TOP (HB4)
13	Collector BOT (HB4)
16	Gate BOT (HB4)
17	Emitter BOT (HB4)

type "GAL"

as type "GB" except
- PIN X1-4: connect this pin to GND
- TOP switch does not exist

type "GAR"

as type "GB" except
- PIN X1-2: connect this pin to GND
- BOTTOM switch does not exist

- 1) Open collector output, external pull up resistor necessary
- 2) When using option "U" the analog temperature signal is not available
- 3) GND aux = reference for analog output signals
- 4) „high“ (min) 11,2 V
„low“ (max) 5,4 V

Case S4

SKiiPPACK 4 - GB

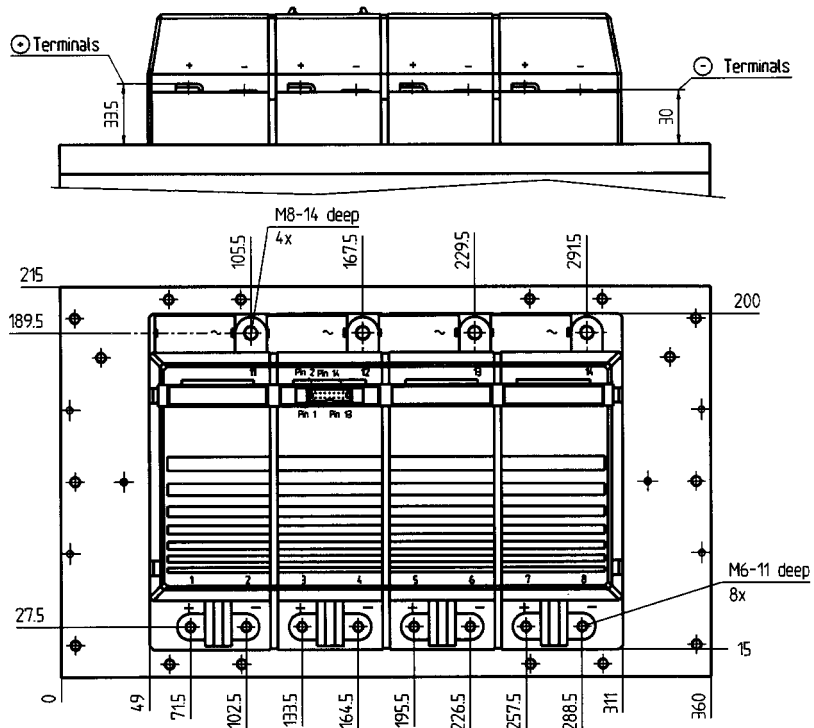
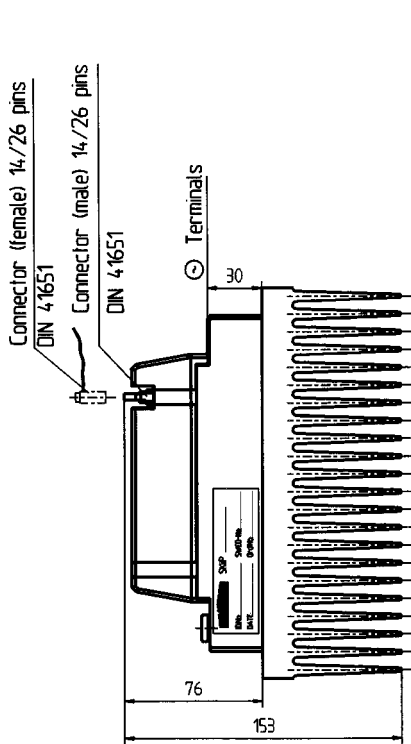

Weight without heatsink: 3,54 kg

P16: 8,46 kg

SKiiPPACK 4 - GB with F-option

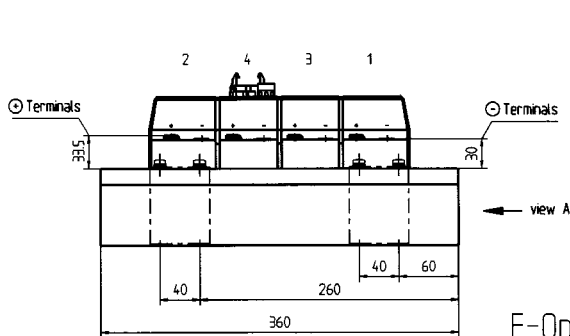

F-Option

