

Power Bridge Rectifiers

SKB 30 SKD 30

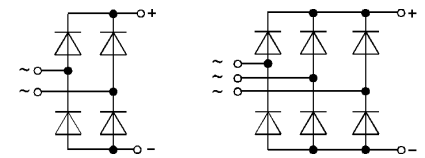

SKB

SKD

Features

- Isolated metal case with screw terminals
- Blocking voltage to 1600 V
- High surge currents
- **SKB** = single phase bridge rectifier
- **SKD** = three phase bridge rectifier
- Easy chassis mounting
- UL recognized, file no. E 63 532

Typical Applications

- Single and three phase rectifiers for power supplies
- Input rectifiers for variable frequency drives
- Rectifiers for DC motor field supplies
- Battery charger rectifiers

V _{RSM} V _{RRM} V	I _D (T _{case} = . . .)			
	30 A (94 °C)		30 A (98 °C)	
	Types	R _{min} Ω	Types	R _{min} Ω
200	SKB 30/02 A1	0,15	SKD 30/02 A1	0,15
400	SKB 30/04 A1	0,3	SKD 30/04 A1	0,3
800	SKB 30/08 A1	0,5	SKD 30/08 A1	0,5
1200	SKB 30/12 A1	0,75	SKD 30/12 A1	0,75
1400	SKB 30/14 A1	0,9	SKD 30/14 A1	0,9
1600	SKB 30/16 A1	1	SKD 30/16 A1	1

Symbol	Conditions	SKB 30	SKD 30	Units
I _D	T _{amb} = 45 °C; isolated ¹⁾ chassis ²⁾ P5A/100 R4A/120 P1A/120	6,5 15 21 23 29	6,5 15 21 23 31	A A A A A
I _{DCL}	T _{amb} = 35 °C; P1A/120 F T _{amb} = 45 °C; isolated ¹⁾ chassis ²⁾ P5A/100 P1A/120 T _{amb} = 35 °C; P1A/120 F	38 6 13 17 24 32	6,5 15 21 31	A A A A A A
I _{FSM}	T _{vj} = 25 °C, 10 ms T _{vj} = 150 °C, 10 ms	370 320		A A
i ² t	T _{vj} = 25 °C, 8,3...10 ms T _{vj} = 150 °C, 8,3...10 ms	680 500		A ² s A ² s
V _F	T _{vj} = 25 °C; I _F = 150 A	2,2		V
V _(TO)	T _{vj} = 150 °C	0,85		V
r _T	T _{vj} = 150 °C	1,2		mΩ
I _{RD}	T _{vj} = 25 °C; V _{RD} = V _{RRM} T _{vj} = 150 °C; V _{RD} = V _{RRM}	0,3 5		mA mA
t _{rr}	T _{vj} = 25 °C	typ. 25		μs
f _G		2000		Hz
R _{thjc}	total	0,7		°C/W
R _{thch}	total	0,1		°C/W
R _{thja}	isolated ¹⁾ chassis ²⁾ P5A/100 P1A/120	8,5 3,3 2,2 1,4		°C/W °C/W °C/W °C/W
T _{vj}		- 40...+ 150		°C
T _{stg}		- 55...+ 150		°C
V _{isol}	a.c. 50...60 Hz; r.m.s.; 1 s / 1 min	3000 / 2500		V
RC	P _R = 1 W	50 0,1		Ω μF
F _u		25		A
M ₁	to heatsink	SI units 5 ± 15 % US units 44 ± 15 %		Nm lb. in.
M ₂	to terminals	SI units 1,5 ± 15 % US units 13 ± 15 %		Nm lb.in.
w		1 2 5		g
Case		G 12	G 13	

¹⁾ Freely suspended or mounted on an insulator

²⁾ Mounted on a painted metal sheet of min. 250 x 250 x 1 mm

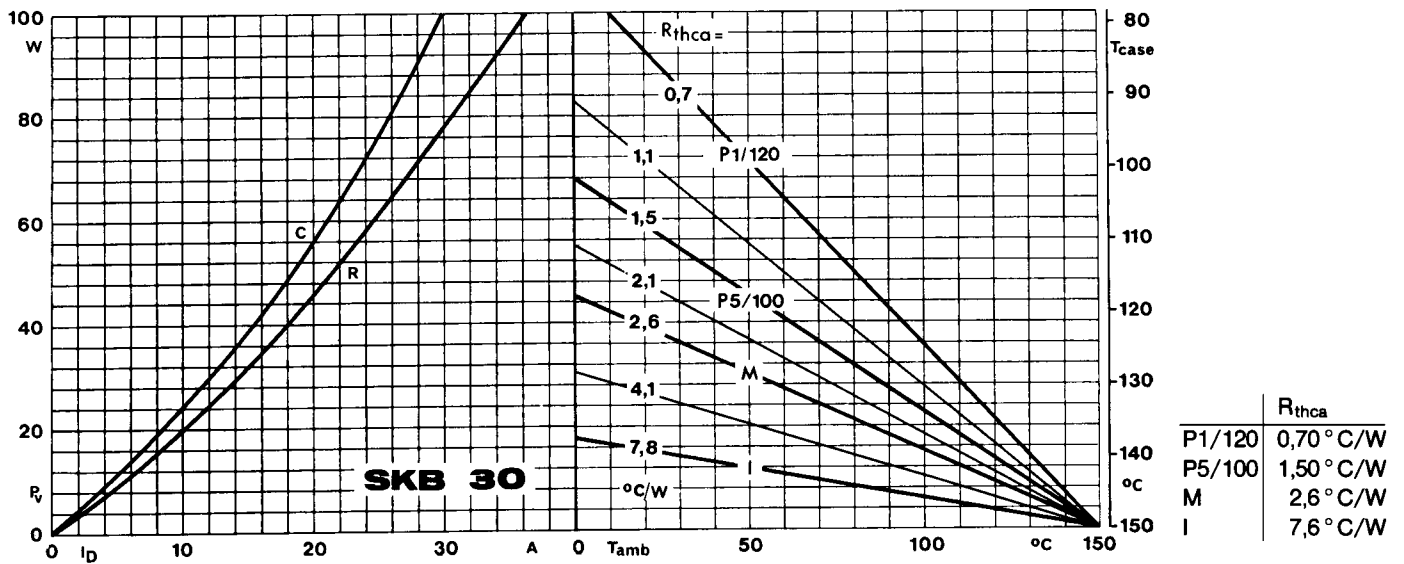

Fig. 3 a Power dissipation vs. output current and case temperature

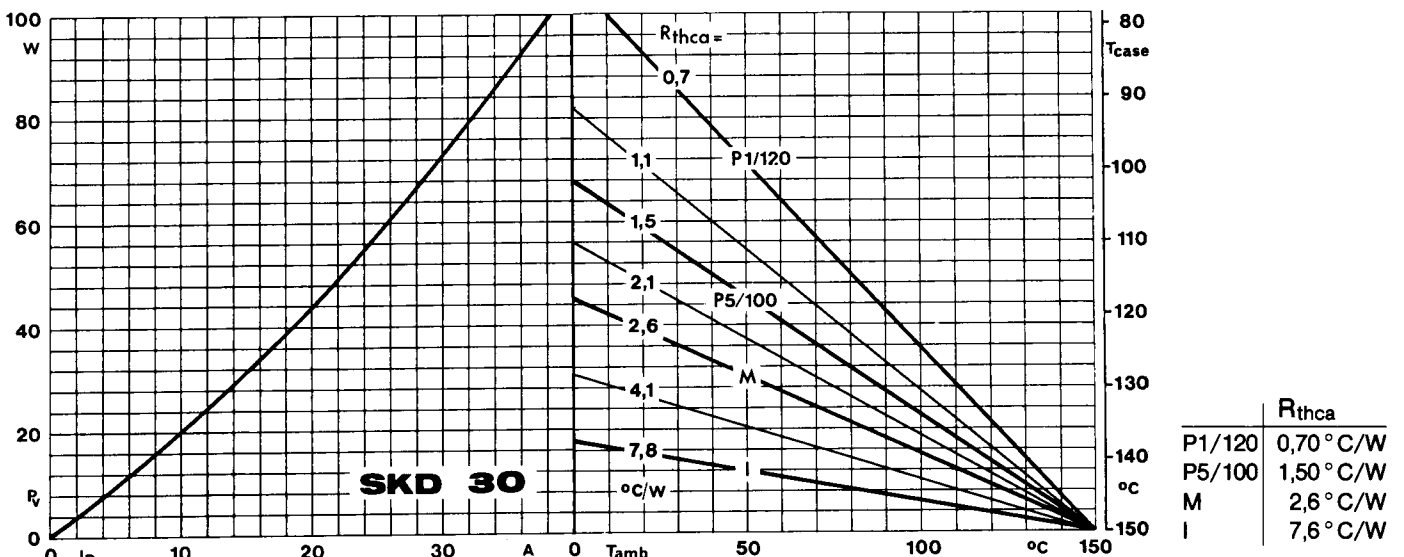

Fig. 3 b Power dissipation vs. output current and case temperature

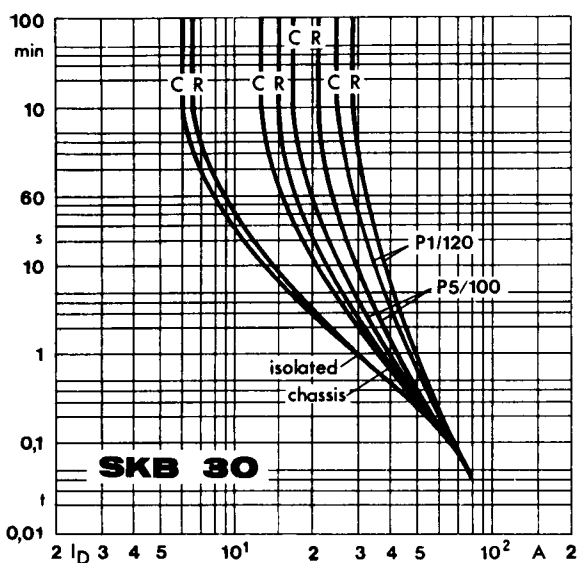

Fig. 6 a Rated overload current vs. time

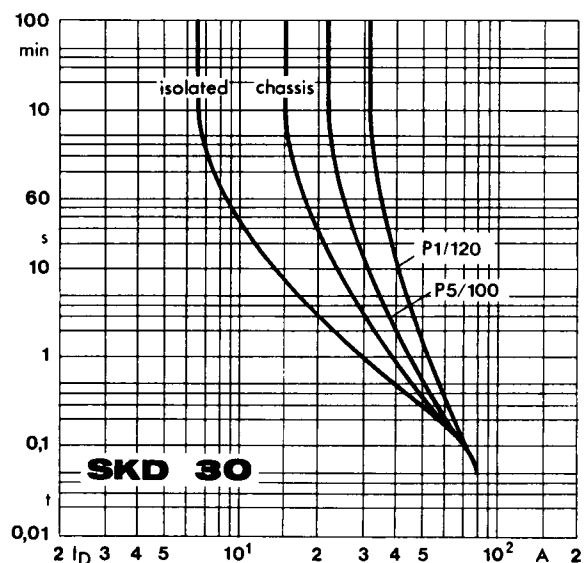

Fig. 6 b Rated overload current vs. time

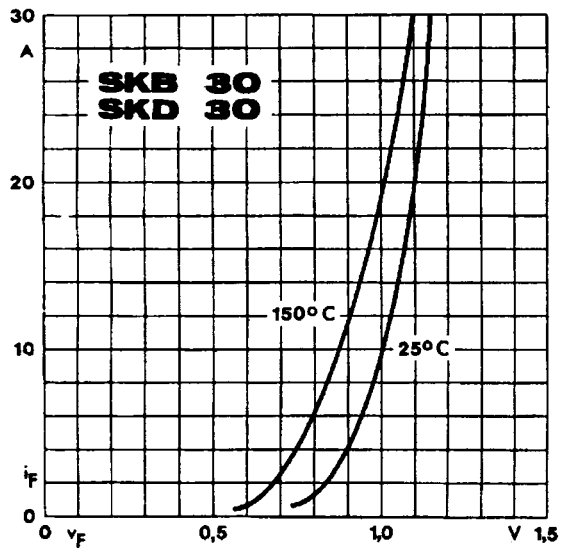
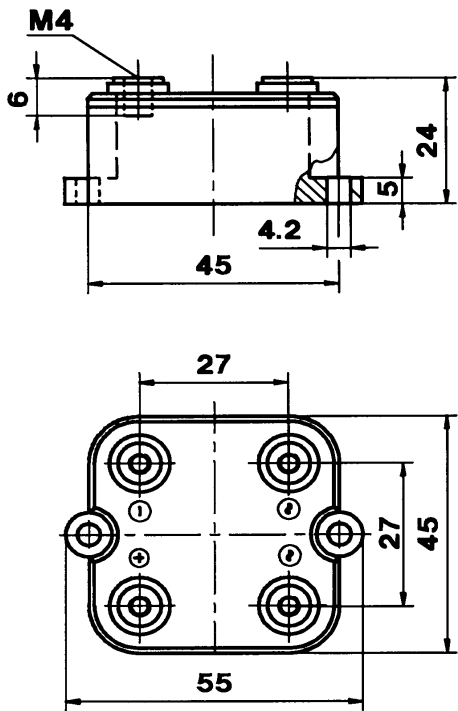

Fig. 9 Forward characteristics of a single diode

SKB 30
Case G 12



Dimensions in mm

SKD 30
Case G 13

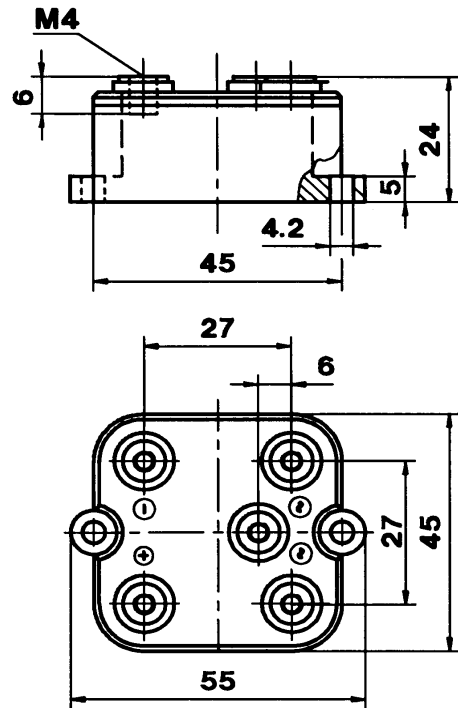

Dimensions in mm